

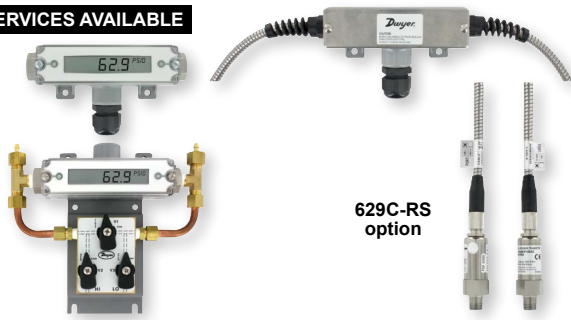

WET/WET DIFFERENTIAL PRESSURE TRANSMITTERS

0.5% Accuracy, NEMA 4X (IP66) Enclosure

CALIBRATION SERVICES AVAILABLE



Conduit housing with remote sensor available in 10' or 20' shielded or armored cable

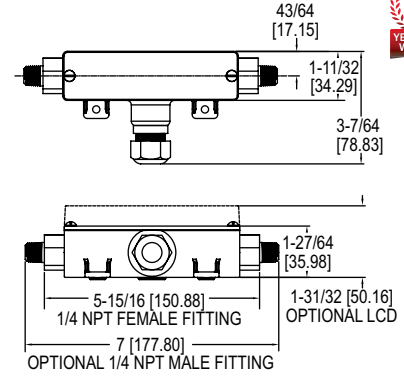

The Series 629C Wet/Wet Differential Pressure Transmitters monitor differential pressure of air and compatible gases and liquids with 0.5% accuracy. The design employs dual pressure sensors converting pressure changes into a standard 4-20 mA output signal or field selectable voltage. Small internal volume and minimal moving parts result in exceptional response and reliability. The terminal block, as well as a zero adjustment button, are easily accessed under the top cover. The Series 629C Differential Pressure Transmitter is designed to meet NEMA 4X (IP66) construction.

BENEFITS/FEATURES

- Powered by either DC or AC - take advantage of most readily available power source reducing installation costs
- Optional LCD does not need a separate power supply - lowers installed cost
- Selectable voltage range - provides flexible choice for changing design or inputs for process/HVAC controllers being used to monitor and control
- Push-button zero (versus trim pot) - more simple zeroing provides easy install and calibration reducing installation time and possibility of operator error
- Optional LCD indicator provides local status to identify operational condition
- Remote sensor option reduces installation labor and material

APPLICATIONS

- Flow elements
- Heat exchangers
- Filters
- Coils
- Chiller
- Pumps

SPECIFICATIONS

Service: Compatible gases and liquids.
Wetted Materials: Without valve: 316, 316L SS. Additional wetted parts with valve option: Buna-N, silicone grease, PTFE, brass 360, copper, and reinforced copolymer.
Accuracy: ±0.5% FS (includes linearity, hysteresis and repeatability).
Stability: ±1% FS/year.
Temperature Limits: 0 to 200°F (-18 to 93°C).
Compensated Temperature Limits: 0 to 175°F (-18 to 79°C).
Pressure Limits: See range table.
Thermal Effects: Avg 0.04%/°F (0.072%/°C) (includes zero and span).
Power Requirements: 2-wire: 10-35 VDC; 3-wire: 13-35 VDC or isolated 16-33 VAC (reverse polarity protected).
Output Signal: 2-wire: 4-20 mA; 3-wire: Field selectable 0-5, 1-5, 0-10, or 2-10 VDC.
Zero and Units: Push-buttons inside conduit enclosure.
Response Time: 400 msec.
Loop Resistance: Current output: 0 to 1250 Ω (max), Rmax = 50(Vps-10); Voltage output: Minimum load resistance = 5 kΩ.
Current Consumption: 28 mA (max).
Electrical Connections: Removable terminal block; 1/2" female NPT conduit.
Process Connections: 1/4" female or male NPT.
Display: Optional 4-1/2 digit LCD field attachable display.
Enclosure Rating: Designed to meet NEMA 4X (-RS maintains NEMA 4X on sensors and housing).
Mounting Orientation: Not position sensitive.
Weight: 629C-XX-CH: 10.1 oz (286 g); 629C-XX-R2-P1-E5-XX: 2.3 lbs (1.04 kg); 629C-XX-R6-P1-E5-XX: 4.55 lbs (2.06 kg).
Compliance: CE.

MODEL CHART

Example	629C	-01	-CH	-P1	-E1	-S1	-3V	629C-01-CH-P1-E1-S1-3V
Series	629C							Wet/wet differential pressure transmitter
Range		01 02 03 04 05 06 07 08 09 11 12 13 14 15 16 17 18 19						0 to 5 psid 0 to 10 psid 0 to 25 psid 0 to 50 psid 0 to 100 psid 0 to 150 psid 0 to 200 psid 0 to 300 psid 0 to 500 psid 0 to 0.5 bar differential 0 to 1 bar differential 0 to 2 bar differential 0 to 4 bar differential 0 to 6 bar differential 0 to 10 bar differential 0 to 15 bar differential 0 to 20 bar differential 0 to 30 bar differential
Housing			CH R1 R2 R5 R6					Conduit housing, NEMA 4X (IP66) Conduit housing, NEMA 4X (IP66) with remote sensor and 10' shielded cable Conduit housing, NEMA 4X (IP66) with remote sensor and 20' shielded cable Conduit housing, NEMA 4X (IP66) with remote sensor and 10' armored cable Conduit housing, NEMA 4X (IP66) with remote sensor and 20' armored cable
Process Connection				P1 P2 P3 P4				1/4" male NPT 1/4" female NPT 1/4" male BSPT 1/4" female BSPT
Electrical Connection					E1 E2 E3 E5 E9			Cable gland with 3' of prewired cable Cable gland with 6' of prewired cable Cable gland with 9' of prewired cable 1/2" female NPT conduit M-12 4 pin connector
Signal Output						S1 S3		4-20 mA Field selectable 0-5, 1-5, 0-10, 2-10 VDC
Options							3V AT FC LCD NIST	3-way valve Aluminum tag Factory calibration certificate LCD indication NIST traceable certificate

Note: -3V option is only available with -P2 process connection.

RANGE

Range Number	Range	Working Pressure*	Over Pressure
01	0 to 5 psid	10 psi	50 psi
02	0 to 10 psid	20 psi	50 psi
03	0 to 25 psid	50 psi	120 psi
04	0 to 50 psid	100 psi	250 psi
05	0 to 100 psid	200 psi	500 psi
06	0 to 150 psid	300 psi	750 psi
07	0 to 200 psid	400 psi	1000 psi
08	0 to 300 psid	600 psi	1200 psi
09	0 to 500 psid	1000 psi	2000 psi
11	0 to 0.5 bar differential	1 bar	3 bar
12	0 to 1 bar differential	2 bar	8 bar
13	0 to 2 bar differential	4 bar	8 bar
14	0 to 4 bar differential	8 bar	18 bar
15	0 to 6 bar differential	12 bar	18 bar
16	0 to 10 bar differential	20 bar	50 bar
17	0 to 15 bar differential	30 bar	60 bar
18	0 to 20 bar differential	40 bar	80 bar
19	0 to 30 bar differential	60 bar	120 bar

*Pressures exceeding the working pressure limit may cause a calibration shift of up to ±3% of full-scale.
 Note: Over pressure of all models with 3-way valve is 100 psi.

ACCESSORIES

Model	Description
A-155	Cable gland with 1/2" NPT male
A-228	12" SS flex hose
A-62X-LCD	Field-upgradeable LCD
BBV-1B	Mini SS 3-valve block manifold

USA: California Proposition 65
 ⚠️ **WARNING:** This product can expose you to chemicals including Lead, which is known to the State of California to cause cancer and birth defects or other reproductive harm. For more information go to www.P65Warnings.ca.gov.