

ML7420A8088-E

Electric Linear Valve Actuator

SPECIFICATION DATA



FEATURES

- Easy and quick installation
- No separate linkage and adjustments required
- Low power consumption and maintenance-free
- Self-adaption function
- Force-limiting end stops
- Manual operation knob
- 0(2)~10 Vdc input and 2~10 Vdc position feedback signal
- Direct/ Reverse action adjustable
- Stroke position on signal failure selectable
- Corrosion-resistant design

SPECIFICATIONS

GENERAL

The ML7420A actuators are designed for modulating control with controllers providing an analog output of 2...10 Vdc. They operate Honeywell's standard valves in heating, ventilation, and air conditioning (HVAC) applications.

Temperature Limits

Ambient operating limits	-10~+50 °C at 5~95% r.h.
Ambient storage limits	-40...+70 °C at 5...95% r.h.
Medium temperature	Max. 150 °C (220 °C with High-Temperature kit)

Signals

Signal input voltage	y=0~10 Vdc or 2~10 Vdc Ri=100 KΩ
Signal source	1 KΩ max.
Position feedback signal	x=2~10Vdc(fully extended)
Load	1 mA max.

Safety

Protection class	III as per EN60730-1
Protection standard	IP54 as per EN60529
Flame retardant housing	V0 as per UL94 (with metal cable gland)

Material

Cover	ABS-FR
Base	glass fiber reinforced plastic
Yoke	aluminum diecast

Wiring

Wiring terminals	1.5 mm ²
Cable entry	M20.
	Two additional knock-outs M18 and M20 for auxiliary switch and potentiometer accessories

Table 1. Selection

Model Number	ML7420A8088-E
supply voltage	24 Vac ±15%; 50/60 Hz
power consumption	5 VA
signal input 0(2) Vdc	Actuator stem retracted. Two-way valve:"open", three-way valve port A-AB:"closed" ①
signal input 10 Vdc	Actuator stem extended. Two-way valve:"closed", three-way valve port A-AB:"open" ①
rated stroke	20mm
run time at 50 Hz	1 min
close-off force	≥ 600 N
spring return time	—
spring return direction	—
weight	1.3 Kg

① Factory setting; can be reversed by pressing the right-hand pushbutton (W3) located on the PCB (see Fig. 1).

OPERATION

General

The drive of a synchronous motor is converted into linear motion of the actuator stem via a spur gear transmission. The actuator stem is connected with the valve stem by a button-keyed retainer connection.

An integrated spring package limits the stem force to a factory-set value in either direction.

The actuator switches off precisely when the specified stem force is reached.

Manual Operation

Actuators without spring return are equipped with a manual operation knob used in case of power failure. Manual operation is permitted only after the power supply is switched off or disconnected.

To operate, push the manual operation knob down and turn clockwise to move the stem downward and counterclockwise to move the stem upward. If the actuator returns to automatic control, the manual operation knob unlocks automatically.

Override Option

All actuators have an integrated override function (see wiring). When the override signal is applied, the actuator drives to the fully-open or fully-closed position, regardless of the controller signal.

Electrical Installation

The actuators are delivered with a pre-installed cable gland M20 and two additional knock-outs for M18 and M20.

Max. cable length/diameter for field mounting: 200 m / 1.5 mm²

NOTE: To avoid malfunction, it is necessary to connect 24 Vac power and ground (see wiring).

Go into self-adaption mode

Mount the actuator on the valve and electrified.

Press down W2 and W3 at the same time more than 2 s, then LED begin to flash, and actuator go into self-adaption process. The actuator will work one whole stroke automatically, then the LED stops flashing and self-adaption completed. The actuator will return to the position before self-adaption process.

NOTE: Self-adaption mode needs to be manually got into which will work only one whole stroke of the actuator.

Input Signal Range

The range of the analog input signal Y can be changed by pressing the right-hand pushbutton (W2) located on the printed circuit board (see Fig. 1). If the corresponding LED is lit, this indicates that the actuator is set for 0...10 V operation (factory setting); if it is dark, the actuator is set for 2...10 V operation.

Input Signal Failure

Using the potentiometer (W1) located on the printed circuit board (see Fig. 1), the actuator can be adjusted such that in case of a signal input failure (e.g. a broken wire), the actuator will run to any pre-configured position between 0% and 100%. The factory setting is with the actuator stem in the central position (50%).

NOTE: The two pushbuttons (W3 and W2) and the potentiometer (W1) are accessible after the cover has been removed and are located at the rear side of the protection sheet of the printed circuit board.

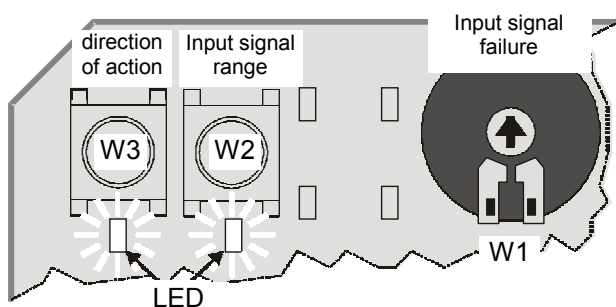

Fig. 1. Pushbuttons and potentiometer (default positions)

Output Signal "POSITION"

An analog output signal 2...10 Vdc "POSITION" is available which represents the actual actuator position. It can be used for remote indication.

When the actuator stem is fully extended, the output signal is 10 Vdc.

Action

The direction of action can be reversed by pressing the left-hand pushbutton (W3) located on the printed circuit board (see Fig. 1). If the corresponding LED is lit, this indicates that the actuator stem will retract at a control signal of 0(2) Vdc (factory setting); if it is dark, the actuator stem will extend at a control signal of 0(2) Vdc.

Accessories

Auxiliary Switches

The actuators can be equipped on-site with an auxiliary switch unit with two switches. Their switching points are adjustable over the full length of the actuator stroke. The switches can be used to switch pumps or provide remote indication of any stroke position. A cable gland M20 is delivered with the unit.

Part number: 43191680-205

High-Temperature Kit

(for application $\geq 150^{\circ}\text{C}$ medium temperature)

Part number: 43196000-001
43196000-002

CLOSE-OFF PRESSURE RATINGS

stem force		600 N					
stroke		20 mm					
valve size	mm	25	32	40	50	65	80
	inch	1	1 ¼	1 ½	2	2 ½	3
valves		close-off pressure ratings (kPa)					
V5011P		1000	700	640	260		
V5211F						1000	1000
V5328A					1000	1000	1000
V5013P			700	460	260		
V5329A						160	100

DIMENSIONS

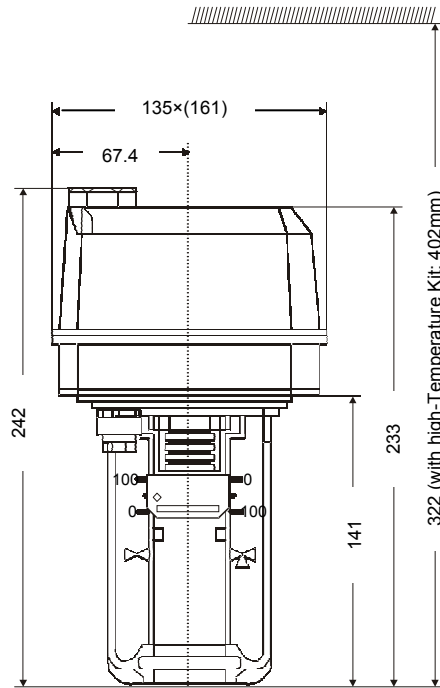
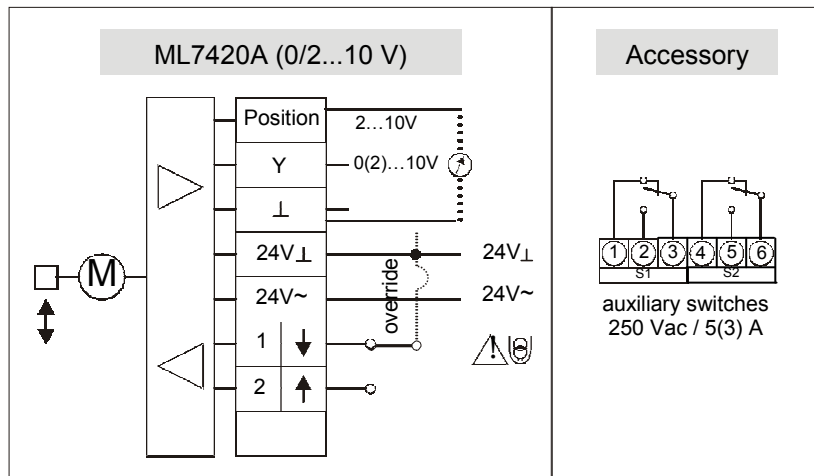

Fig. 2. ML7420A (mm)

WIRING



Honeywell

Automation and Control Solutions

Honeywell (Tianjin) Limited
 No. 158, NanHai Road
 Tianjin Economic-Technological Development Area
 Tianjin, 300457, P.R.C.
 Phone: +86-22-66287000
 Fax: +86-22-25325214

<https://dlk.com.vn/>

Email: info@dlk.com.vn